

- (a) $\frac{1}{\sin i}$ (b) $\frac{3}{4 \sin i}$
 (c) $\frac{4}{3 \sin i}$ (d) $\frac{4 \sin i}{3}$

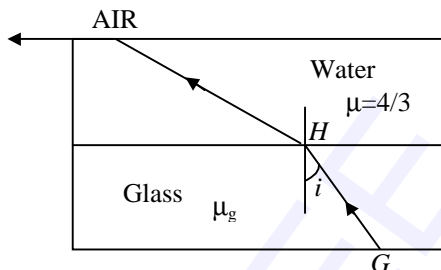

➤ We have

$$\frac{4}{3} \sin C = 1$$

Again $\mu_g \sin i = \frac{4}{3} \sin C = 1$

$$\therefore \mu_g = \frac{1}{\sin i}$$

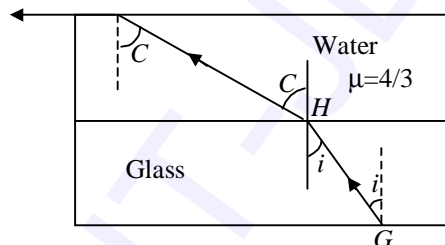

3. Two rods of lengths l_1 (aluminum) and l_2 (steel) having thermal co-efficient of linear expansion α_A and α_S respectively are connected end to end. Change in temperature ΔT produces equal changes in their lengths. The ratio $\frac{l_1}{l_1 + l_2}$ is

- (a) $\frac{\alpha_A}{\alpha_S}$ (b) $\frac{\alpha_A}{\alpha_A + \alpha_S}$
 (c) $\frac{\alpha_S}{\alpha_A + \alpha_S}$ (d) α_A

➤ $\Delta l_{1(t)} = l_1 \alpha_A \Delta T$

$$\Delta l_{2(t)} = l_2 \alpha_S \Delta T$$

According to question,

$$l_1 \alpha_A = l_2 \alpha_S$$

$$\frac{l_1}{l_1 + l_2} = \frac{\alpha_S}{\alpha_A + \alpha_S}$$

4. A point charge is placed symmetrically inside a thick conducting shell. The electric lines of force can be sketched as

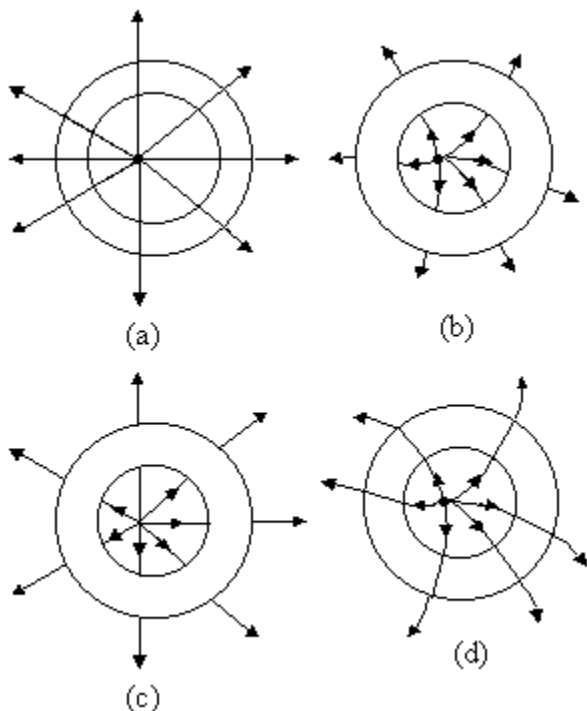

- Electric field inside conductor is zero. This property rules out options (a) & (d).
 Electric field line converges on or diverges from the conducting surface normally.
 This property eliminates option (c). ∴ **(b)**

5. A block of mass $\sqrt{3}$ kg is placed on a rough horizontal surface $\mu = \frac{1}{2\sqrt{3}}$. A force is applied as shown in the figure. Minimum force required just to slide the block is
 (a) $20/3$ N **(b) 20 N**
 (c) 5 N (d) 10 N

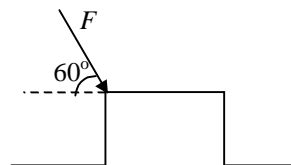

- We have

$$N = 10\sqrt{3} + \frac{\sqrt{3}}{2} F$$

and
$$\frac{F}{2} = \frac{1}{2\sqrt{3}} \left(10\sqrt{3} + \frac{\sqrt{3}}{2} F \right)$$

⇒
$$F = 20\text{N}$$

6. A particle is moving on a circular path in the horizontal plane with constant angular speed. The angular momentum will be constant about a point
 (a) on the circumference (b) anywhere outside the circle
 (c) anywhere inside the circle **(d) on the center**

- $\vec{L} = \vec{r} \times \vec{p}$; since $|\vec{p}| = \text{constant}$
 $\therefore L$ is constant when $|\vec{r}|$ is constant.

7. Arrange the power consumed in the following circuits in decreasing order (all resistors are identical)

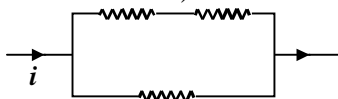

I

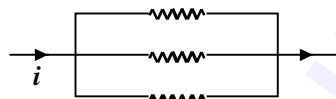

II

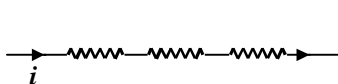

III

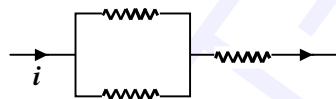

IV

- (a) $I > II > III > IV$
 (c) $IV > III > II > I$

- (b) $III > IV > I > II$
 (d) $II > III > I > IV$

- If current is constant, power is maximum if R of the circuit is maximum. Series circuit (III) has maximum R and parallel circuit (II) has minimum R . Only option (b) satisfies this criterion.

8. Source S produces a gravitational field. Work done in moving a mass from A to B via paths I, II and III are W_1 , W_2 and W_3 respectively. Choose the correct option.

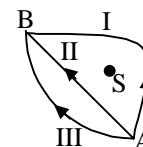

- (a) $W_1 = W_2 = W_3$ (b) $W_1 > W_2 > W_3$
 (c) $W_1 < W_2 < W_3$ (d) $W_1 > W_3 > W_2$

- Since gravitational field is conservative, the work done is independent of path.

9. A massless rod of length 1 m is hanged from the ceiling at one end and the other end is connected to the weight W . Cross-sectional area of the wire is 10^{-6} m^2

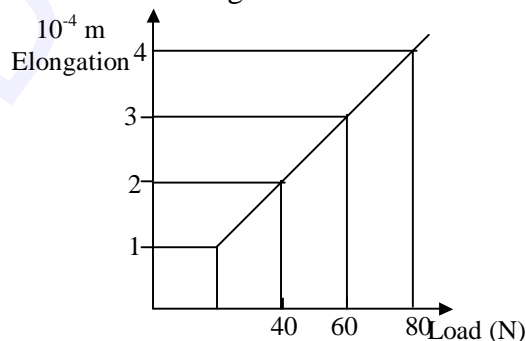

- Potential energy (U) is given by $\frac{1}{2}kx^2$, hence it is maximum at $x = \pm A$ and zero at $x = 0$.

Again, $U = \frac{1}{2}kA^2 \cos^2 \omega t$.

Therefore it is maximum at $t = 0$ and $t = T/2$ and so on. \therefore (I) and (III).

12. A plane wave front of light is incident on a plane mirror as shown in the figure. Intensity is maximum at P when

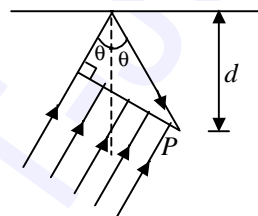

- (a) $\cos \theta = \frac{3\lambda}{2d}$ (b) $\cos \theta = \frac{\lambda}{4d}$
 (c) $\sec \theta - \cos \theta = \frac{3\lambda}{4d}$ (d) $\sec \theta - \cos \theta = \frac{\lambda}{2d}$

- The path difference between the disturbance reaching at point P directly and after reflection (from the geometry of figure) = $d \sec \theta \cos 2\theta + d \sec \theta + \frac{\lambda}{2}$;

Here $\frac{\lambda}{2}$ is due to the reflection from denser medium.

For maximum intensity

$$d \sec \theta (\cos 2\theta + 1) + \frac{\lambda}{2} = n\lambda$$

or $\cos \theta = \frac{\lambda}{4d}$

13. The attractive potential for an atom is given by $V = V_0 \ln \frac{r}{r_0}$, V_0 and r_0 are

constants and r is the radius of orbit. The radius r_n of the n th Bohr's orbit depends on principal quantum number n as

- (a) $r_n \propto n$ (b) $r_n \propto \frac{1}{n^2}$
 (c) $r_n \propto n^2$ (d) $r_n \propto \frac{1}{n}$

➤ $V = V_0 \log_e \frac{r}{r_0}$

$$F = -q \frac{dV}{dr} = -q \frac{V_0}{r}$$

$$\frac{mv^2}{r} = q \frac{V_0}{r}$$

$$mv^2 = qV_0$$

which means that v is constant.

$$mvr = \frac{nh}{2\pi}$$

which means that $r \propto n$ as v is constant.

14.

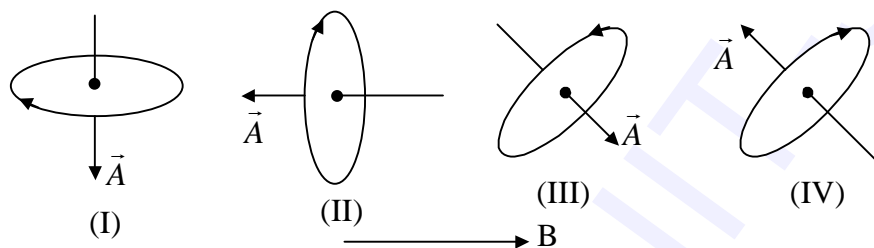

In the above diagram, a current carrying loop is placed in different orientations in a uniform magnetic field whose direction is as shown. The correct order of loop's potential energy is

(a) $II > I > IV > III$

(b) $I > II > III > IV$

(c) $II > IV > I > III$

(d) $IV > III > II > I$

➤ Potential energy is

$$U = -\vec{p}_m \cdot \vec{B}$$

(I) $U = 0$

(II) $U = iAB$

(III) $U = -iAB \cos \theta$

(IV) $U = iAB \cos \theta$

Where θ is the angle between \vec{A} and \vec{B} .

15. An ideal gas undergoes a cyclic process ABCA as shown in the P-T diagram. The process CA is adiabatic. Which one of the following PV diagrams correctly depicts the same process?

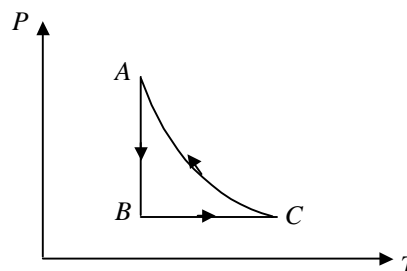

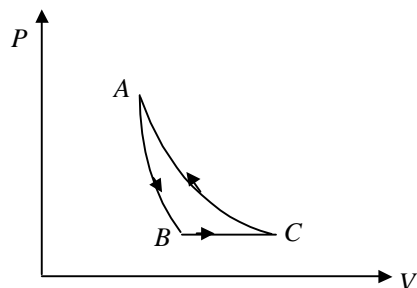

(a)

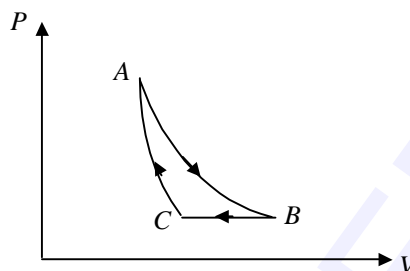

(b)

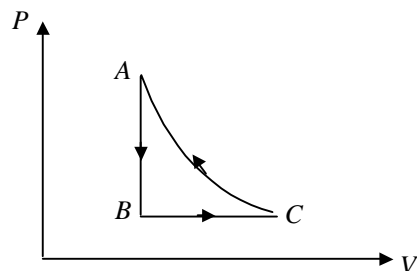

(c)

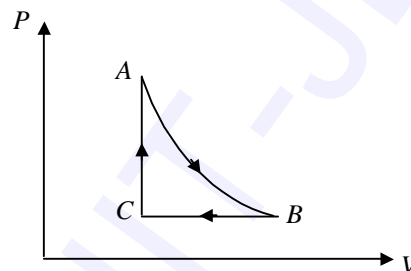

(d)

- The question seems to be incorrect.
 As for an adiabatic process,

$$\frac{dP}{dT} = \frac{\gamma P}{\gamma - 1 T}$$

Which is positive for an ideal gas. Every student is expected to be awarded benefit marks.

16. Two identical bodies of mass m are connected by a light rod of length l and placed on horizontal smooth surface. An impulse mv is given at one end perpendicular to the length of the rod. The angular velocity of the system is

- (a) $\frac{2v}{L}$ (b) $\frac{4v}{L}$
 (c) $\frac{v}{4L}$ (d) $\frac{v}{L}$

- Applying Conservation of Angular Momentum,

$$\frac{mvL}{2} = \left(\frac{mL^2}{4} + \frac{mL^2}{4} \right) \omega$$

$$\therefore \omega = \frac{v}{L}$$



20. A positive charge is moving along positive x-direction. From origin it follows trajectory (non-circular) as shown in the figure. The electric and magnetic field existing in the region to the right of y-axis may be (a, b, c are non-zero positive constants)

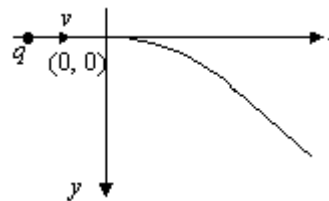

- (a) $\vec{E} = 0, \vec{B} = a\hat{i} + c\hat{k}$
 (b) $\vec{E} = 0, \vec{B} = b\hat{j} + c\hat{k}$
 (c) $\vec{E} = a\hat{i}, \vec{B} = a\hat{i} + c\hat{k}$
 (d) $\vec{E} = a\hat{i}; \vec{B} = b\hat{j} + c\hat{k}$
- For non-circular curves electric field should be present and because trajectory is in x-y plane, the magnetic field should be out of the page and/or in x-direction. The z-direction has not been specified. If the z-direction is into the page, the correct answer should be $\vec{E} = a\hat{i}, \vec{B} = a\hat{i} - c\hat{k}$

Every student is expected to awarded benefit marks.

21. Volume V of a nucleus is related to the mass M as

- (a) $V \propto M^3$ (b) $V \propto \sqrt[3]{M}$
 (c) $V \propto M$ (d) $V \propto \frac{1}{M}$
- Radius of nucleus is given by $r = A^{1/3}r_0$
 $\therefore \text{volume} = \frac{4}{3}\pi r^3 \Rightarrow V \propto A \propto M$

22. A cylindrical tube partially filled with water produces fundamental frequency when height of air column is 0.1 m. When the level of water is lowered, the next harmonic is observed at 0.35 m. The end correction is

- (a) 0.025 m (b) 0.015 m
 (c) 0.001 m (d) 0.002 m
- For first resonance $l_1 + e = \frac{\lambda}{4}$
 For second resonance, $l_2 + e = \frac{3\lambda}{4}$

So
$$e = \frac{l_2 - 3l_1}{2} = 0.025 \text{ m}$$

23. Two bodies of same mass and surface area raised to a temperature T are allowed to cool in the same environment. The curve of temperature versus time is as shown in the figure. Emissivity and absorbtivity are e_x, e_y and A_x and A_y respectively. Then

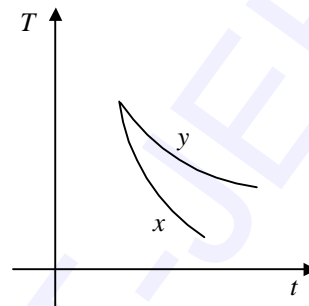

- (a) $e_x > e_y; A_x > A_y$
 (b) $e_x < e_y; A_x > A_y$
 (c) $e_x > e_y; A_x < A_y$
 (b) $e_x < e_y; A_x < A_y$

- Rate of cooling

$$\frac{dT}{dt} = \frac{eA}{mc} [T^4 - T_o^4]$$

$$\therefore e \propto \frac{dT}{dt}$$

$$\therefore \text{For } x, \frac{dT}{dt} \text{ is more therefore } e_x > e_y$$

and since absorbtivity is proportional to emissivity.

Hence $A_x > A_y$

24. The edge of a cube is measured to be 1.2×10^{-2} m. Its volume should be recorded as:

- (a) $1.728 \times 10^{-6} \text{ m}^3$ (b) $1.73 \times 10^{-6} \text{ m}^3$
 (c) $1.70 \times 10^{-6} \text{ m}^3$ (d) $1.7 \times 10^{-6} \text{ m}^3$

- Since the significant figure in the edge of the cube is 2.

\therefore The expression for volume should be having the same significant figure.

25. A convex lens of focal length 30.00 cm forms an image of height 2.00 cm of an object placed at infinity. Now a concave lens of focal length 20.00 cm is placed at a distance of 26.00 cm to the side in which image is formed. The height of image formed by the combined system of the same object is

- (a) 2.50 cm (b) 1.25 cm
 (c) 2.00 cm (d) 1.00 cm

- For concave lens,

$$f = -20 \text{ cm}$$

$$u = +4 \text{ cm}$$

$$m = \frac{F}{u + F} = \frac{-20}{+4 - 20} = \frac{-20}{-16} = \frac{5}{4}$$

$$\frac{I}{O} = \frac{v}{4} = \frac{5}{4}$$

$$I = +2.5 \text{ cm}$$

∴ (a)

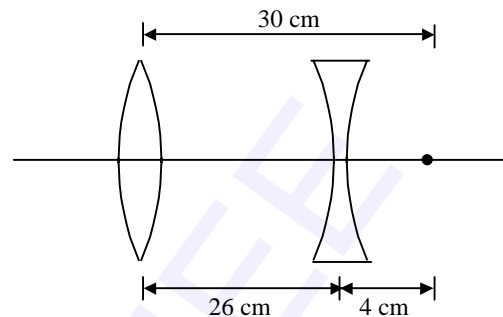

26. An a.c. voltage $E = E_0 \sin 100 t$ is applied to the circuit, the phase difference between current and voltage is found to be $\pi/4$, then

- (a) $R = 1 \text{ k}\Omega$; $C = 1 \mu\text{F}$
 (b) $R = 1 \text{ k}\Omega$; $C = 10 \mu\text{F}$
 (c) $R = 100 \Omega$; $L = 10 \text{ H}$
 (d) $R = 1 \text{ k}\Omega$; $L = 1 \text{ H}$

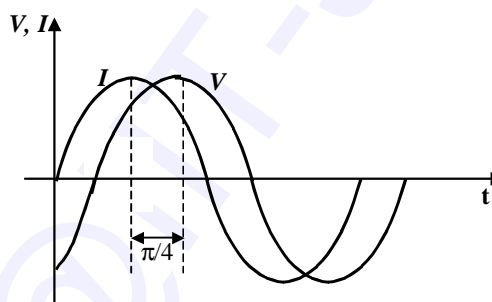

- Voltage and current relation from the graph confirms that the circuit is RC-circuit

whose power factor is $\frac{1}{\sqrt{2}}$, which can be justified only by taking $R = 1 \text{ k}\Omega$ and $C = 10 \mu\text{F}$.

27. The ratio of radius of ${}_{100}\text{Fm}^{257}$ atom (assuming Bohr's model to be valid) to the Bohr radius is

- (a) 257 (b) 100
 (c) 1/4 (d) 4

- Since the outermost orbit number is 5 and

$$r_n = \frac{n^2}{Z} r_H = \frac{1}{4} r_H$$

28. A stationary nucleus (mass number 220) decays by emitting an α -particle. The total energy released is 5.5 MeV. The kinetic energy carried by the α -particle is

- (a) 5.4 MeV (b) 5.6 MeV
 (c) 4.4 MeV (d) 6.5 MeV

- Applying law of conservation of linear momentum and using the energy released, velocity of α -particle and daughter nucleus can be calculated.

Therefore, kinetic energy of α particle

$$= \frac{220-4}{220} \times 5.5 \text{ MeV} = 5.4 \text{ MeV.}$$

Maths

Break-up of questions:

Algebra	Trigonometry	Co-ordinate Geometry	Calculus	Vector/3D
9 (32%)	1 (4%)	6 (21%)	10 (36%)	2 (7%)

1. If $|z| = 1, z \neq -1$, then the real part of $\omega = \frac{z-1}{z+1}$ is

- | | |
|--------------------------------------------------------------------------------------|---------------------------------------------------------------|
| <p>(a) $\frac{-1}{ z+1 ^2}$</p> <p>(c) $\frac{1}{ z+1 ^2}$</p> | <p>(b) $\frac{\sqrt{2}}{ z+1 ^2}$</p> <p>(d) 0</p> |
|--------------------------------------------------------------------------------------|---------------------------------------------------------------|



Put $z = x+iy$, rationalise and proceed.

2. The area of the quadrilateral formed by the tangents at the extremities of latus

recta of $\frac{x^2}{9} + \frac{y^2}{5} = 1$ is

- | | |
|---------------------------------------------------------------------------|----------------------------|
| <p>(a) $\frac{27}{4}$</p> <p>(c) $\frac{27}{2}$</p> | <p>(b) 9</p> <p>(d) 27</p> |
|---------------------------------------------------------------------------|----------------------------|



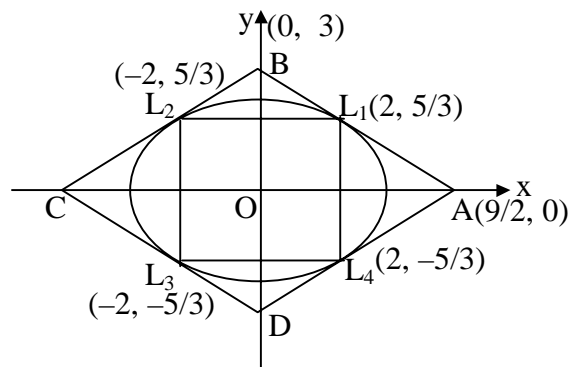

Equation of tangent at L_1 is $\frac{2x}{9} + \frac{y}{3} = 1$

Equation of tangent at L_2 is $-\frac{2x}{9} + \frac{y}{3} = 1$

Equation of tangent at L_3 is $-\frac{2x}{9} - \frac{y}{3} = 1$

Equation of tangent at L_4 is $\frac{2x}{9} - \frac{y}{3} = 1$

From figure area = 27 sq. unit

3. The domain of $\sqrt{(\sin^{-1} 2x) + \frac{\pi}{6}}$ is

(a) $\left[-\frac{1}{4}, \frac{1}{2}\right]$

(b) $\left[-\frac{1}{2}, \frac{1}{2}\right]$

(c) $\left[-\frac{1}{2}, \frac{1}{4}\right]$

(d) $\left[-\frac{1}{4}, \frac{1}{4}\right]$



$$\sin^{-1}(2x) + \pi/6 \geq 0$$

$$\Rightarrow \sin^{-1} 2x \geq -\pi/6$$

$$\Rightarrow -\sin \frac{\pi}{6} \leq 2x \leq 1$$

$$\Rightarrow -\frac{1}{4} \leq x \leq \frac{1}{2}$$

$$\Rightarrow \text{Domain is } \left[-\frac{1}{4}, \frac{1}{2}\right].$$

4. The range of $f(x) = \frac{x^2 + x + 2}{x^2 + x + 1}$, $x \in R$ is

- (a) $[1, \infty)$ (b) $\left(1, \frac{11}{7}\right)$
 (c) $\left[1, \frac{7}{5}\right]$ (d) $\left(1, \frac{7}{3}\right]$

➤ Let $y = f(x)$, form a quadratic in x and use $D \geq 0$ for real x .

5. The slope of the focal chords of the parabola $y^2 = 16x$ which are tangents to the circle $(x - 6)^2 + y^2 = 2$ are

- (a) ± 1 (b) ± 2
 (c) $-1/2, 2$ (d) $-2, 1/2$

➤ Equation of focal chord: $y = m(x - 4)$

Thus
$$\frac{|0 - m(6 - 4)|}{\sqrt{1 + m^2}} = \sqrt{2}$$

Squaring both sides and solving

$\Rightarrow m = \pm 1$

6. Coefficient of t^{24} in $(1 + t^2)^{12} (1 + t^{12}) (1 + t^{24})$ is

- (a) $2 + {}^{12}C_6$ (b) ${}^{12}C_6$
 (c) $1 + {}^{12}C_6$ (d) $3 + {}^{12}C_6$

7. $f(x) = \frac{x}{1+x}, [0, \infty) \rightarrow [0, \infty)$ is

- (a) both one-one and onto (b) one-one but not onto
 (c) not one-one but onto (d) neither one-one nor onto

➤
$$f'(x) = \frac{1+x-x}{(1+x^2)^2} = \frac{1}{(1+x)^2}$$

$\Rightarrow f$ is increasing $\Rightarrow f$ is one-one. Range of $f = [0, 1) \Rightarrow f$ is into.

8. The function f defined by $f(x) = \int_{x^2}^{x^2+1} e^{-t^2} dt, x \in R$ increases in the interval

- (a) $x < 0$ (b) $x > 0$
 (c) $x \in (-2, 2)$ (d) nowhere



$$f'(x) = (2x)e^{-(x^2+1)^2} - 2xe^{-x^4} > 0, \text{ for } f \text{ increasing}$$

$$= 2x \left[e^{-(x^2+1)^2} - e^{-x^4} \right] > 0$$

$$\text{As } e^{-(x^2+1)^2} < e^{-x^4}, \forall x$$

$$\therefore x < 0$$

9. Let $S = \{1, 2, 3, 4, 5, 6\}$. Two numbers are chosen without replacement. The probability that minimum of the two numbers is less than 4 is

- (a) $\frac{1}{15}$ (b) $\frac{14}{15}$
 (c) $\frac{4}{5}$ (d) $\frac{1}{5}$



The required probability = $1 - P$ (both the numbers are more than or equal to 4)

$$= 1 - \left[\frac{3}{6} \times \frac{2}{5} \right]$$

$$= \frac{4}{5}$$

- 10.

For natural numbers m and n , if $I_{m,n} = \int_0^1 t^m (1+t)^n dt$, then $I_{m,n}$ is equal to

- (a) $\frac{2^n}{m+1} - \frac{n}{m+1} I_{(m+1, n-1)}$ (b) $\frac{2^n}{m+1} + \frac{n}{m+1} I_{(m+1, n-1)}$
 (c) $\frac{n}{m+1} I_{(m+1, n-1)}$ (d) $\frac{m}{n+1} I_{(m+1, n-1)}$



$$I_{m,n} = \int_0^1 t^m (1+t)^n dt = \frac{t^{m+1}}{m+1} (1+t)^n \Big|_0^1 - \int_0^1 \frac{t^{m+1}}{m+1} n(1+t)^{n-1} dt$$

$$= \frac{2^n}{m+1} - \frac{n}{m+1} I_{m+1, n-1}$$

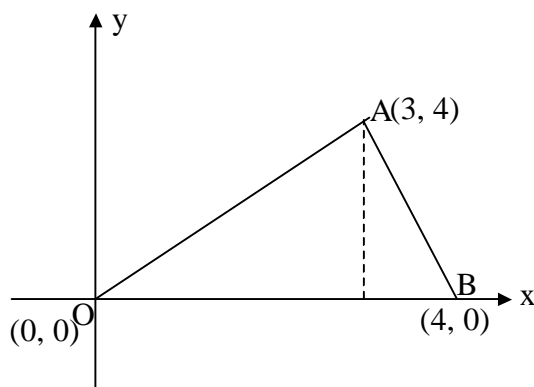

Equation of altitude from A is $x = 3$
 Equation of altitude from O is $x = 4y$
 \therefore orthocentre is $(3, 3/4)$

14. The value of k , for which the line $\frac{x-4}{1} = \frac{y-2}{1} = \frac{z-k}{2}$ lies on the plane $2x - 4y + z = 7$
- (a) $k = 7$ (b) $k = -7$
 (c) $k = 1$ (d) no value of k

For $k = 7$, the point $(4, 2, k)$ lies on the plane.
 Further the line is perpendicular to the normal of the plane. Hence $k = 7$ is the required value.

15. The system $x + \alpha y = 0, y + \alpha z = 0, z + \alpha x = 0$ has infinitely many solutions when
- (a) $\alpha = 1$ (b) $\alpha = -1$
 (c) $\alpha = 0$ (d) no real value of α

$$\begin{vmatrix} 1 & \alpha & 0 \\ 0 & 1 & \alpha \\ \alpha & 0 & 1 \end{vmatrix} = 0$$

Solve for α .

16. In which of the following functions Lagrange's mean value theorem is not applicable in $[0, 1]$

19. If n is a non-zero integer and $\lim_{x \rightarrow 0} \frac{\sin nx [n(a-n)x - \tan x]}{x^2} = 0$, then a equals
- (a) 0 (b) $1/n$
 (c) $\frac{n+1}{n}$ (d) $n + \frac{1}{n}$



$$\lim_{x \rightarrow 0} \frac{\sin(nx)(n(a-n)x - \tan x)}{x^2} = 0$$

$$\Rightarrow \lim_{x \rightarrow 0} \frac{\sin(nx)}{nx} \times n \times \left\{ \frac{n(a-n)}{1} - \frac{\tan x}{x} \right\} = 0$$

$$\Rightarrow n^2(a-n) - n = 0 \Rightarrow a = n + \frac{1}{n}$$

20. If $y(t)$ is the solution of $(t+1) \frac{dy}{dt} - ty = 1$, $y(0) = -1$, then $y(1)$ is
- (a) $-\frac{1}{2}$ (b) $e - \frac{1}{2}$
 (c) $e + \frac{1}{2}$ (d) $\frac{1}{2}$



The given differential equation can be rewritten as

$$\frac{dy}{dt} - \frac{t}{t+1}y = \frac{1}{t+1}$$

Which is a linear differential equation.

21. The volume of the parallelepiped formed by the vertices $\hat{i} + a\hat{j} + \hat{k}$, $\hat{j} + a\hat{k}$, $a\hat{i} + \hat{k}$ is minimum for ($a > 0$)
- (a) $a = \frac{1}{3}$ (b) $a = \frac{1}{\sqrt{3}}$
 (c) $a = \sqrt{3}$ (d) $a = 3$



Volume of parallelepiped

$$= \begin{vmatrix} 1 & a & 1 \\ 0 & 1 & a \\ a & 0 & 1 \end{vmatrix} = 1 \cdot 1 \cdot 1 - a \cdot (-a^2) + 1 \cdot (-a)$$

Proceed using maxima and minima method.....

22. The value of θ for which the sum of the intercept on the axis by the tangent at the point $(3\sqrt{3} \cos \theta, \sin \theta)$, $0 < \theta < \pi/2$, of the ellipse $\frac{x^2}{27} + y^2 = 1$ is least, is
- (a) $\pi/6$ (b) $\pi/3$
 (c) $\pi/4$ (d) $\pi/8$



$$\text{Equation of tangent; } \frac{x \cos \theta}{a} + \frac{y \sin \theta}{b} = 1$$

$$\Rightarrow \text{intercept on x axis} = \frac{a}{\cos \theta}$$

$$\Rightarrow \text{intercept on y axis} = \frac{b}{\sin \theta}$$

$$\text{Sum of the intercept} = \frac{3\sqrt{3}}{\cos \theta} + \frac{1}{\sin \theta} = f(\theta), \text{ as } 0 < \theta < \pi/2$$

$f(\theta)$ is minimum for $\theta = \pi/6$.

23. The number of integer points strictly inside the triangle formed by $(0, 0)$, $(0, 21)$ and $(21, 0)$ is
- (a) 231 (b) 190
 (c) 105 (d) 133



$$x + y \leq 20$$

$$x \geq 1$$

$$y \geq 1$$

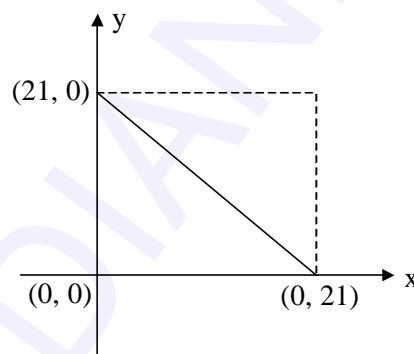

$$\begin{aligned} \text{Number of integral points } (x, y) &= 19 + 18 + \dots + 1 \\ &= 190 \end{aligned}$$

24. $f(x) = x^2 + 2bx + 2c^2$, $g(x) = -x^2 - 2cx + b^2$. Find the condition for which minimum value of $f(x)$ is greater than maximum value of $g(x)$

- (a) $|c| > \sqrt{2} |b|$ (b) $0 < c < b\sqrt{2}$
 (c) $b\sqrt{2} < c < 0$ (d) no values of b and c



$$f(x) = (x+b)^2 + 2c^2 - b^2 \Rightarrow f(x)_{\min} = 2c^2 - b^2$$

$$g(x) = -(x+c)^2 + b^2 + c^2 \Rightarrow g(x)_{\max} = b^2 + c^2$$

$$2c^2 - b^2 > b^2 + c^2 \Rightarrow c^2 > 2b^2 \Rightarrow |c| > \sqrt{2} |b|.$$

25. Let A, B, C be three events and $\bar{A}, \bar{B}, \bar{C}$ be the corresponding complementary events. Given $P(B) = 3/4$, $P(A \cap B \cap \bar{C}) = 1/3$ and $P(\bar{A} \cap B \cap \bar{C}) = 1/3$, then $P(B \cap C) = ?$

- (a) 1/12 (b) 1/9
 (c) 1/15 (d) 1/18



$P(B \cap C) = P(B) - P(A \cap B \cap \bar{C}) - P(\bar{A} \cap B \cap \bar{C}) = 1/12$. Draw Venn diagram and see the validity of the above expression.

26. Let $f(x)$ be a differentiable function, where $f'(1) = 4$, $f'(2) = 6$, then

$\lim_{h \rightarrow 0} \frac{f(2+2h+h^2) - f(2)}{f(1+h-h^2) - f(1)}$ is equal to

- (a) 3 (b) 3/2
 (c) -3 (d) may not exist



$$\lim_{h \rightarrow 0} \frac{f(2+2h+h^2) - f(2)}{f(1+h-h^2) - f(1)} = \lim_{h \rightarrow 0} \frac{(2+2h)f'(2+2h+h^2)}{(1-2h)f'(1+h-h^2)} = \frac{2f'(2)}{f'(1)} = 3$$

27. Area of the figure bounded by $y = \sqrt{x}$, $x = 2y + 3$ and x-axis in the first quadrant is

- (a) $2\sqrt{3}$ (b) 9
 (c) $\frac{34}{3}$ (d) 18



$$A = \left| \int_0^9 \sqrt{x} dx - \frac{1}{2} \times 6 \times 3 \right| = \left| \left(\frac{x^{3/2}}{3/2} \right)_0^9 - 9 \right| = 9 \text{ sq. unit.}$$

28. Given the family of hyperbolas $\frac{x}{\cos^2 \alpha} - \frac{y}{\sin^2 \alpha} = 1$ for $\alpha \in (0, \pi/2)$ which of the following does not change with varying α ?

- (a) abscissa of foci (b) eccentricity
 (c) equations of directrices (d) abscissa of vertices



$$\sin^2 \alpha = \cos^2 \alpha (e^2 - 1)$$

$$\Rightarrow \cos^2 \alpha \cdot e^2 = 1$$

\therefore abscissa of foci does not change.

Chemistry

Break-up of questions:

Physical	Inorganic	Organic
12 (43%)	5 (18%)	11 (39%)

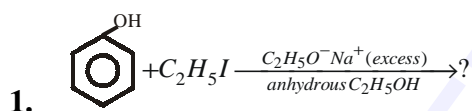

- a) $C_6H_5OC_2H_5$ b) $C_2H_5OC_2H_5$ c) C_6H_5I d) $C_6H_5OC_6H_5$



$C_2H_5O^-$ will abstract proton from phenol converting the latter into phenoxide ion. This would then make nucleophilic attack on the methylene carbon of alkyl iodide. But $C_2H_5O^-$ is in excess. $C_2H_5O^-$ is better nucleophile than $C_6H_5O^-$ (phenoxide) ion since while in the former the negative charge is localised over oxygen and in the latter it is delocalised over the whole molecular framework. So, it is $C_2H_5O^-$ ion that would make nucleophilic attack at ethyl iodide to give diethyl ether (Williamson's synthesis).

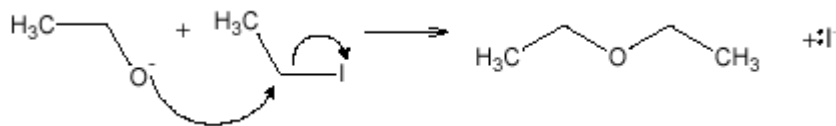

2. The esters P and Q (see fig.) can be distinguished by acid hydrolysis and subsequent reaction with

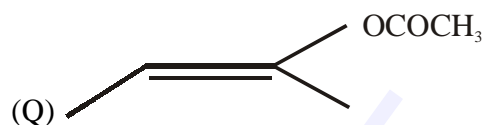
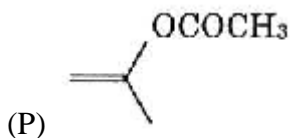

- a) 2, 4 – Dinitrophenyl hydrazine
 c) Fehling solution

- b) Lucas reagent
 d) NaHSO₃

➤ P and Q on acid hydrolysis form aldehyde and ketones respectively. Thus can be distinguished by fehling solution.

3. For the reaction

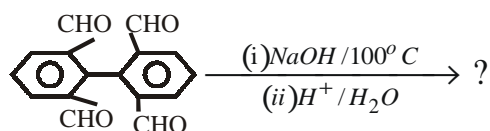

one of the products obtained is

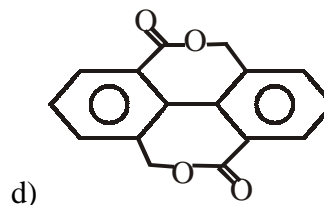
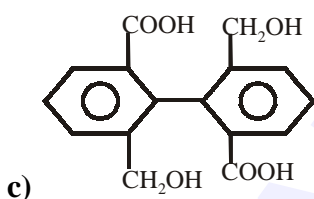
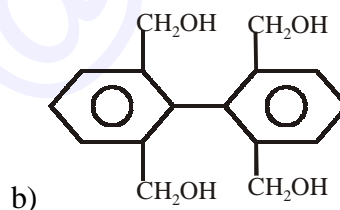
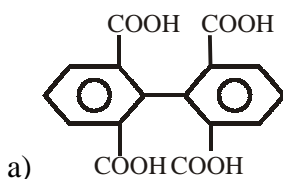

➤ After (i), the intramolecular Cannizaro reaction takes place to form

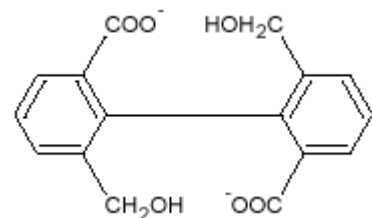

The step (ii) is acid work-up.

4. The formula and colour of the main compound formed on fusing a mixture of MnO₂ and KOH in the presence of air, respectively are

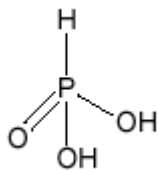

9. The scheme for the extraction of gold from roasted gold ore is given below:

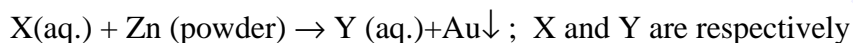
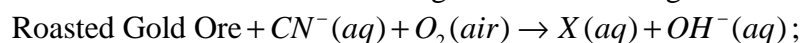

- | | |
|-------------------------------------------------------------------|----------------------------------------------------------------------|
| a) $[\text{Au}(\text{CN})_2]^-$, $[\text{Zn}(\text{CN})_4]^{2-}$ | b) $[\text{Au}(\text{CN})_4]^{3-}$, $[\text{Zn}(\text{CN})_4]^{2-}$ |
| c) $[\text{Au}(\text{CN})_2]^-$, $[\text{Zn}(\text{CN})_6]^{4-}$ | d) $[\text{Au}(\text{CN})_4]^{3-}$, $[\text{Zn}(\text{CN})_6]^{4-}$ |

➤ Coordination no. of Au is 2 and that of Zn is 4.

10. Boric acid H_3BO_3 is a

- | | |
|-------------------------------------|------------------------------------|
| a) Weak Lewis acid and monobasic | b) Strong Lewis acid and monobasic |
| c) Weak Bronsted acid and monobasic | d) Weak Bronsted acid and tribasic |

➤ H_3BO_3 has incomplete octet of B therefore it accepts a pair of electrons, hence weak monobasic Lewis acid.

11. Among the following compound which has the hybridisation $sp^2 - sp^2 - sp - sp$?

- | | |
|---------------------------------------------------------|------------------------------------------------------------|
| a) $\text{CH}_2 = \text{CH} - \text{C} \equiv \text{N}$ | b) $\text{CH}_2 = \text{CH} - \text{CH} = \text{CH}_2$ |
| c) $\text{CH}_2 = \text{C} = \text{C} = \text{CH}_2$ | d) $\text{CH} \equiv \text{C} - \text{C} \equiv \text{CH}$ |

12. The extent of Physisorption of an absorbate increases with

- | | |
|------------------------------------------|------------------------------------------|
| a) Increase in temperature | b) Decrease in temperature |
| c) Decrease in pressure of the absorbate | d) Decrease in surface area of absorbent |

➤ Decrease in temperature increases the liquefaction ability of gases.

13. In an Electrolytic cell electrons flow from

- | | |
|---------------------------------|-------------------------------|
| a) Cathode to anode in solution | b) Cathode to external supply |
| c) Cathode to internal supply | d) Anode to internal supply |

➤ The electrons actually do not flow inside the solution (remember, an electron cannot swim!). However, it is the migration of ions towards oppositely charged electrons that indirectly constitutes the flow of electrons from cathode to anode internally.

14. Which of the following equation represents ΔH_f° correctly

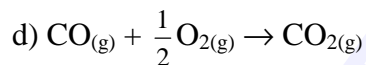
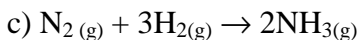
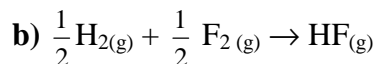
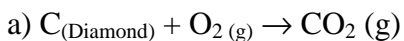

➤ Heat of formation is defined for one mole.

15. For the reaction sequence shown below

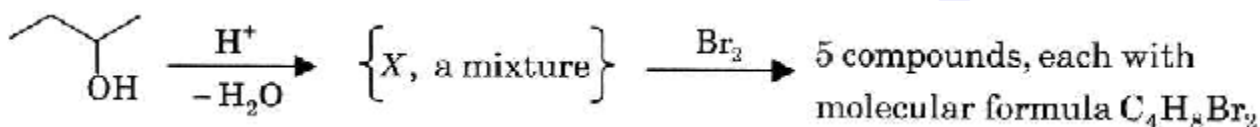

the number of compounds in the mixture X is

a) 2

b) 3

c) 4

d) 5

➤

(B) Mixture contains But-1-ene, cis but-2-ene and trans but-2-ene

16. $C_6H_5-C \equiv C-CH_3 + H_2O \xrightarrow{H_2SO_4/HgSO_4}$ more than one product

The predominant product is:

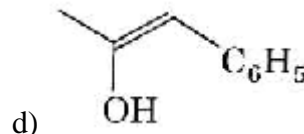
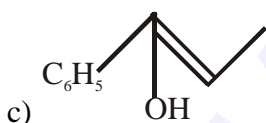
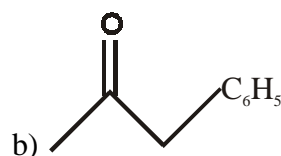
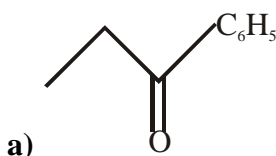

➤

➤ For precipitation

$$K_{IP} > K_{SP}$$

Since K_{SP} of HgS is least at first K_{IP} of HgS becomes greater than its K_{SP} .

20. In the reaction of X with 2 equivalents of $NaNH_2$ where X is

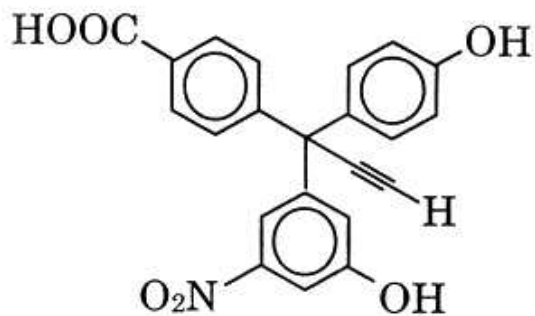

The product is

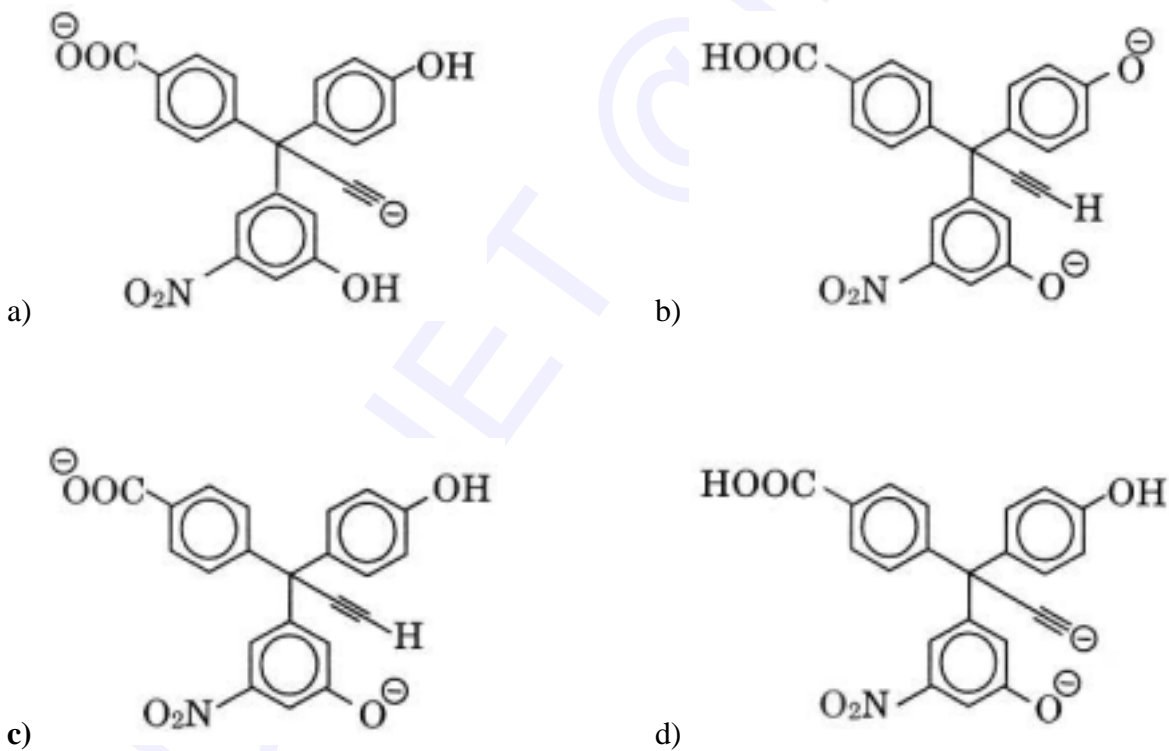

➤ Two moles of NH_2^- ions will abstract two moles of most acidic hydrogen out of the four moles of hydrogen present per mole of the acidic compound.

Acidic order is

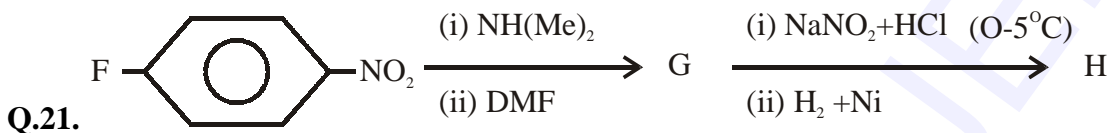
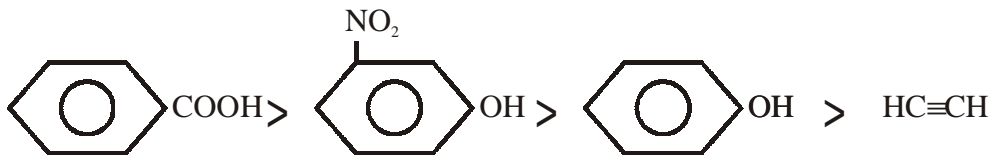

The structure of the final product H is

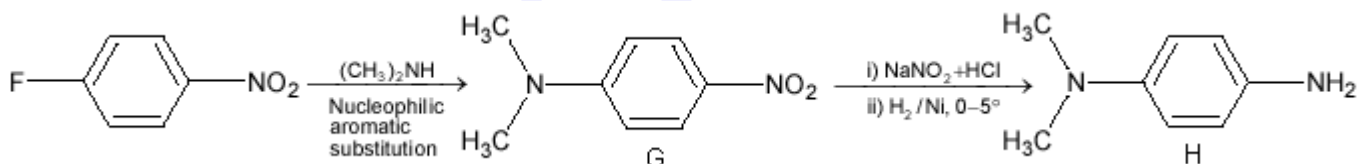
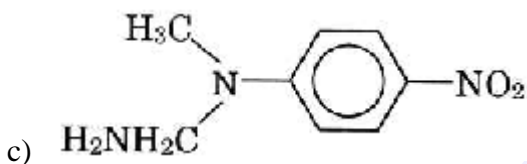
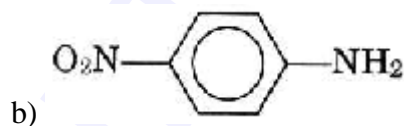

22. In a biologically catalysed oxidation of ethanol, the concentration of ethanol decreases in a first order reaction from 800 mol/dm^3 to 50 mol/dm^3 in $2 \times 10^4 \text{ sec}$. The rate constant λ is

- a) $1.00 \times 10^{-4} \text{ sec}^{-1}$ b) $1.38 \times 10^{-4} \text{ sec}^{-1}$ c) $3.45 \times 10^{-5} \text{ sec}^{-1}$ d) $5.00 \times 10^{-5} \text{ sec}^{-1}$

$$K = \frac{2.303}{t} \log \left(\frac{C_0}{C} \right) = \frac{2.303}{2 \times 10^4} \log \left(\frac{800}{50} \right)$$

23. When ethyl ester is reacted with excess of CH_3MgBr then which of the 3^o alcohols is formed?

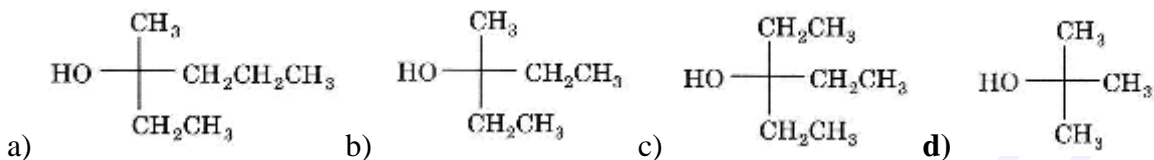

➤ Alkyl group in the final product comes from Grignard's reagent only.

24. A solution (X) is prepared and treated as follows:

Solution (X) = $[\text{Co}(\text{NH}_3)_5\text{Br}]\text{SO}_4$ (0.02 mol) + $[\text{Co}(\text{NH}_3)_5\text{SO}_4]\text{Br}$ (0.02 mol) in 2 litres.

(i) 1 litre solution of (X) + excess $\text{AgNO}_3 \rightarrow$ (Y) mole of $\text{AgBr} \downarrow$

(ii) 1 litre solution of (X) + excess $\text{BaCl}_2 \rightarrow$ (Z) mole of $\text{BaSO}_4 \downarrow$

Y and Z obtained respectively are

a) 0.02, 0.02

b) 0.02, 0.01

c) 0.01, 0.02

d) 0.01, 0.01

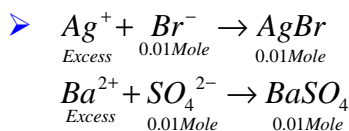

25. Na^{23} is most stable isotope of Sodium: Na^{24} is expected to undergo:

a) α - decay

b) β^- decay

c) β^+ - decay

d) K-e⁻ capture

➤ Na^{24} has higher n/p ratio. Therefore to decrease this value β^- is emitted

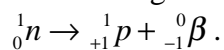

26. When an enantiomerically pure chiral acid reacts with a racemic alcohol containing a single chiral carbon atom, the resultant ester formed will be:

a) pure enantiomer

b) racemic mixture

c) an optically active mixture

d) Meso

➤ The optically active acid reacts with d and l forms of alcohol present in the racemic mixture to form two types of isomeric esters. In each of the configuration, the chiral centre of the acid remains the same. So, the mixture is optically active.

27. Which of the following contains maximum no. of atoms?

a) 24g C

b) 27 g Al

c) 56 g Fe

d) 108g Ag

28. $\text{Si}(\text{CH}_3)_2\text{Cl}_2 + \text{H}_2\text{O}$ (excess) \rightarrow

